



DATASHEET:

HA-PL5 TRAILER

PORTABLE HA-PL5 CHARGER STATION

The HA-PL5 Trailer is a roadgoing charging station, designed to charge, store and deploy portable airfield lights of type HA-PL5. By simply dropping the lights in the charger bays and switching on the battery charger, the portable lights will be charged within <12 hours

TOP STRUCTURE	AlMg4,5 powder coated
COLOUR	Civil Yellow RAL 1021, Military NATO Green RAL 6031 (or any colour on request)
DIMENSIONS	4,02x1,59x1,26 m (see other side for dimensions)
WEIGHT	Complete with lights: 1055 kg Without lights: 600 kg Max allowed: 1300 kg
TIRE SIZE	185/70R13
INPUT VOLTAGE	100-240V
FREQUENCY RANGE	50-60 Hz
PLUG	Standard Euro contact plug
POWER CONSUMPTION	One side loaded (36 HA-PL5 lights): 1100W max Both sides loaded (72 HA-PL5 lights): 2200W max
AC CURRENT AT 240V AC	One side loaded (36 HA-PL5 lights): 7,2 A Both sides loaded (72 HA-PL5 lights): 14,4 A
RECHARGING	<12 hours
INGRESS PROTECTION	IP44 (cover closed)
AMBIENT TEMPERATURE	-20°C to +50 °C
HS CODE (CUSTOMS TARIFF)	87164000



Holland Aviation
Daniëlsweg 40
4451 HW Heinkenszand
The Netherlands

Tel. +31 (0)113 613467
Fax. +31 (0)113 613570
Email: info@hollandaviation.com
www.hollandaviation.com





Holland Aviation b.v.

Airport and heliport, lighting and equipment, windsock assemblies

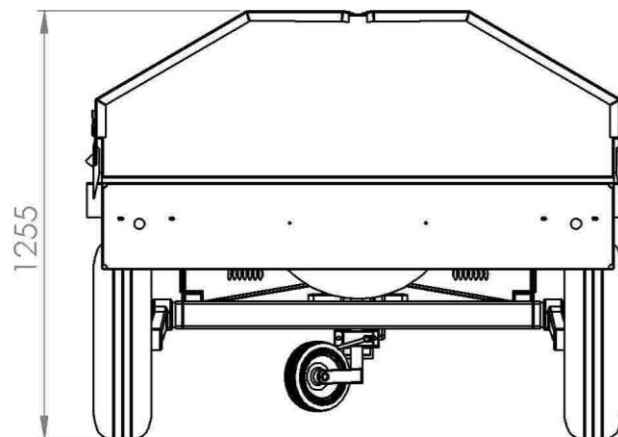
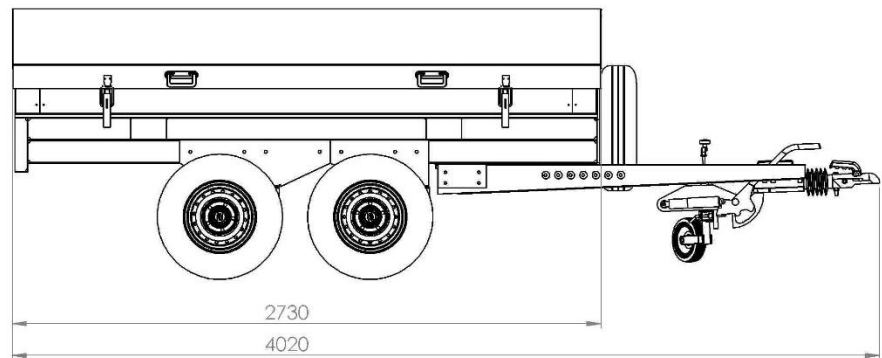
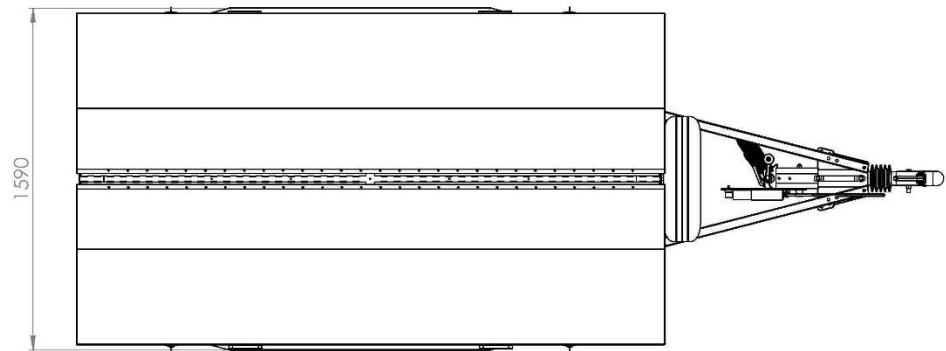

Holland Aviation
Daniëlsweg 40
4451 HW Heinkenszand
The Netherlands

Tel. +31 (0)113 613467
Fax. +31 (0)113 613570
Email: info@hollandaviation.com
www.hollandaviation.com

